

# ANALYSIS OF GLASS RAIL BASE MOLDING ATTACHMENT

<b>Wiss, Janny, Elstner Associates, Inc.</b> 330 Pfingsten Rd., Northbrook Illinois 60062	Made by: <b>NSA</b>	Sheet# <b>1/21</b>
 TACO Metals 50 N.E 179th Street, Miami FL 33162 <b>Glass Rail Base Molding Attachment Analysis</b>	Checked by: <b>MJS</b>	Project # <b>970798</b>
	Date: <b>07/22/97</b>	

## DesignCriteria

The purpose of these calculations is to check the adequacy of the connection of the TACO Metals glass hand railing base shoe molding (two types - see fig. 1) to either a concrete or steel substrate. The analysis considers the adequacy of the connection when when the standard height railing (42 in.) is subjected to live loads required by model building codes. The analysis is limited to the base shoe to substrate connection. Analysis of stresses in the glass, top rail, and base shoe molding are beyond the scope of these calculations.

Analysis of glass railing base shoe connections (4 types considered)

- Case 1: Concrete surface mounted (see fig. 2)
- Case 2: Concrete flush mounted (see fig. 3)
- Case 3: Steel fascia mounted (see fig. 4)
- Case 4: Steel fascia mounted (see fig. 5)

Model Code regulations require a uniform loading of 50 lbs per lineal foot (plf) or a 200-lb concentrated load to be resisted at the top rail, whichever creates the most severe stresses.

For the base shoe connection, the 200-lb load applied in a horizontal direction at the top handrail causes the maximum stresses in the connections.

The analysis considered shear and moment due to the 200 lb load being resisted by 3 - SAE Grade 5, 1/2" diameter cap screws ( $F_u = 120,000$  psi and  $F_y = 92,000$  psi) and 2 - ASTM A307, 3/8" diameter T-bolts ( $F_u = 60,000$  psi)

## Reference Standards

- The Aluminum Associations (AA), *Aluminum Design Manual*, Specifications & Guidelines for Aluminum Structures, October, 1994.
- American Architectural Manufacturers Association (AAMA), *Metal Curtain Wall Fasteners* (AAMA TIR-A9-1991), 1991
- American Concrete Institute (ACI), *Building Code Requirements for Structural Concrete* (ACI 318-95), 1995.
- American Institute of Steel Construction (AISC), *Manual of Steel Construction* (Allowable Stress Design), 9th Edition, 1989.
- Industrial Fasteners Institute (IFI), *Fastener Standards*, 6th Edition, 1988
- International Conference of Building Officials (ICBO), *Uniform Building Code* (UBC), Structural Engineering Design Provisions, Volume 2, 1997.
- Precast/Prestressed Concrete Institute (PCI), *PSI Design Handbook*, MNL 120, 4th Edition, 1992.

Note: Relevant reference to these documents in the calculations is made with [ ] (square brackets).

# ANALYSIS OF GLASS RAIL BASE MOLDING ATTACHMENT

<b>Wiss, Janny, Elstner Associates, Inc.</b> 330 Pfingsten Rd., Northbrook Illinois 60062		Made by: <b>NSA</b>	Sheet# <b>2/21</b>
	<b>TACO Metals</b> 50 N.E 179th Street, Miami FL 33162 <b>Glass Rail Base Molding Attachment Analysis</b>		Checked by: <b>MJS</b>
			Date: <b>07/22/97</b>

Figure 1 - 6063-T6 Aluminum Base Shoe Moldings

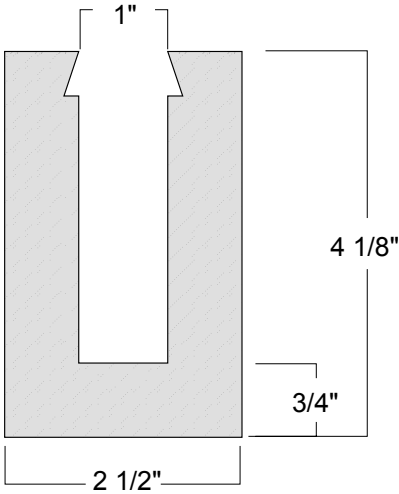
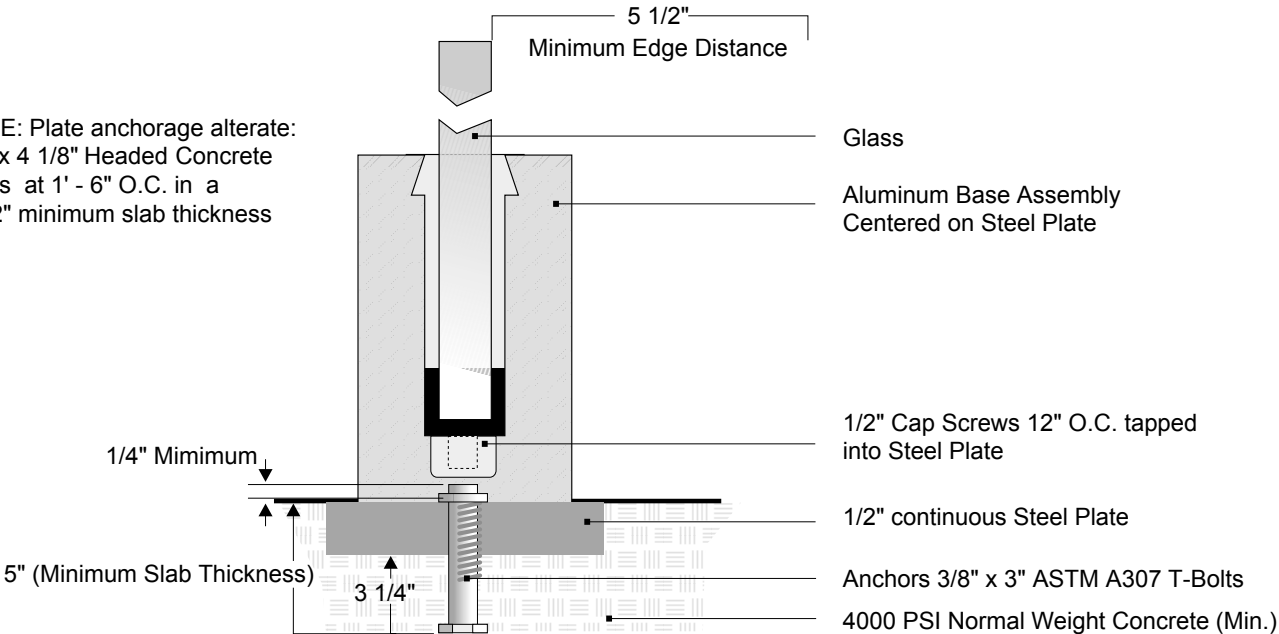



Figure 2 - Surface Mounted Base Shoe Molding

NOTE: Plate anchorage alterate:  
 3/8" x 4 1/8" Headed Concrete  
 Studs at 1' - 6" O.C. in a  
 5 1/2" minimum slab thickness



# ANALYSIS OF GLASS RAIL BASE MOLDING ATTACHMENT

	<b>Wiss, Janny, Elstner Associates, Inc.</b> 330 Pfingsten Rd., Nor thbrook Illinois 60062	Made by: <b>NSA</b>	Sheet # <b>3/21</b>
	<b>TACO Metals</b> 50 N.E 179th Street, Miami FL 33162 <b>Glass Rail Base Molding Attachment Analysis</b>	Checked by: <b>MJS</b>	Project # <b>970798</b>
		Date: <b>07/22/97</b>	

**Figure 3 - Flush Mounted Base Shoe Molding (recessed in concrete)**

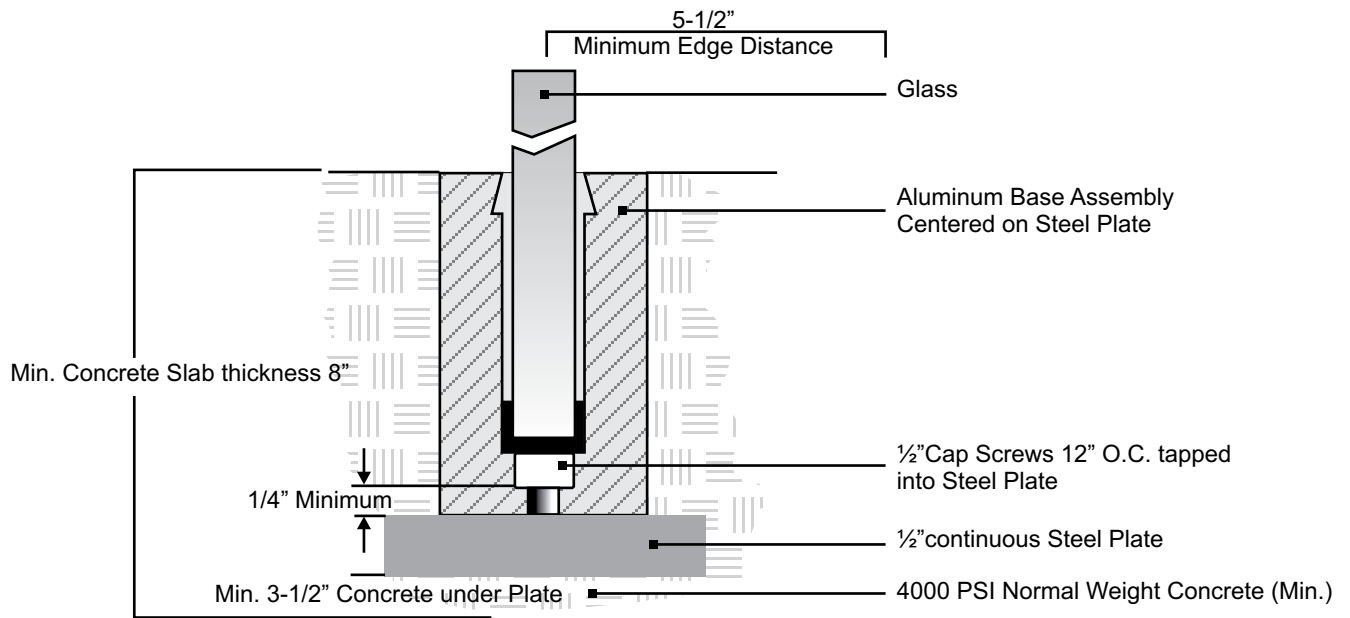

**Figure 4 - Fascia Mounted Base Shoe Molding**

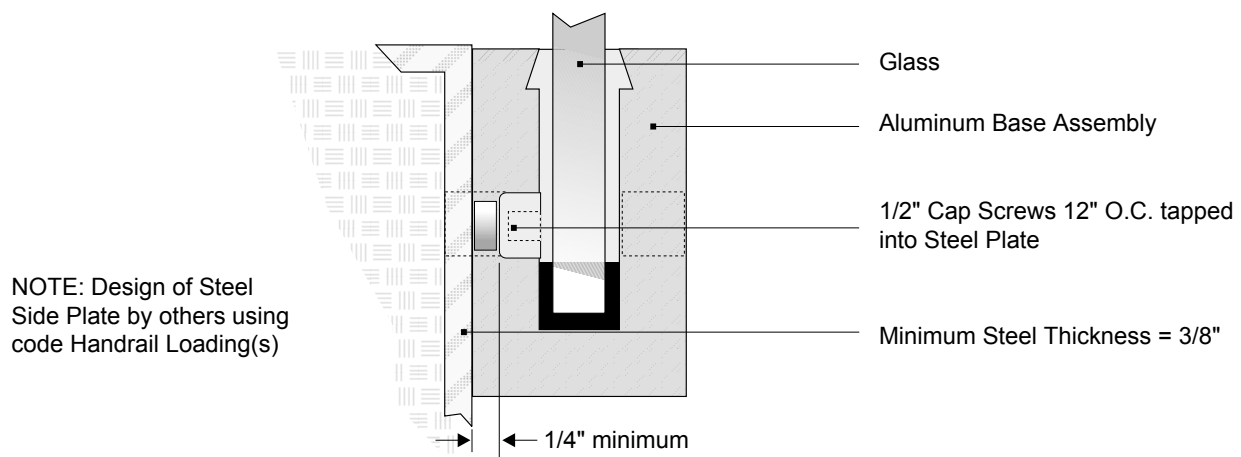

# ANALYSIS OF GLASS RAIL BASE MOLDING ATTACHMENT

<b>Wiss, Janny, Elstner Associates, Inc.</b> 330 Pfingsten Rd., Northbrook Illinois 60062		Made by: <b>NSA</b>	Sheet # <b>4/21</b>	
	<b>TACO Metals</b> 50 N.E 179th Street, Miami FL 33162 <b>Glass Rail Base Molding Attachment Analysis</b>		Checked by: <b>MJS</b>	Project # <b>970798</b>
			Date: <b>07/22/97</b>	

**Figure 5 - Fascia Mounted Base Shoe Molding**

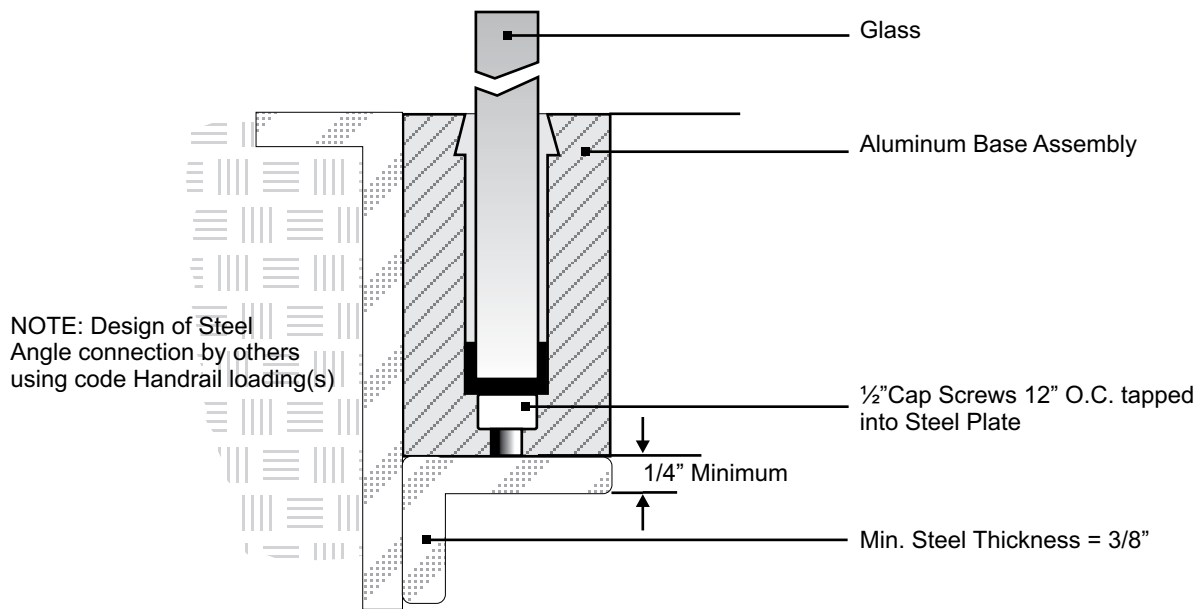

	<b>Wiss, Janny, Elstner Associates, Inc.</b> 330 Pflingsten Rd., Northbrook Illinois 60062  <b>TACO Metals</b> 50 N.E 179th Street, Miami FL 33162 <b>Glass Rail Base Molding Attachment Analysis</b>	Made by: <b>NSA</b>	Sheet # <b>5/21</b>
		Checked by: <b>MJS</b>	Project # <b>970798</b>
		Date: <b>07/22/97</b>	

### Analysis of Glass Railing Base Shoe Connections

Railing Load  
 (Ref: 1997 UBC)  
 per Table 16-B:

Lateral Load 50 lbs/ft  
 Concentrated Load 200 lbs.  
 (not acting cumulatively with the above load)

Application

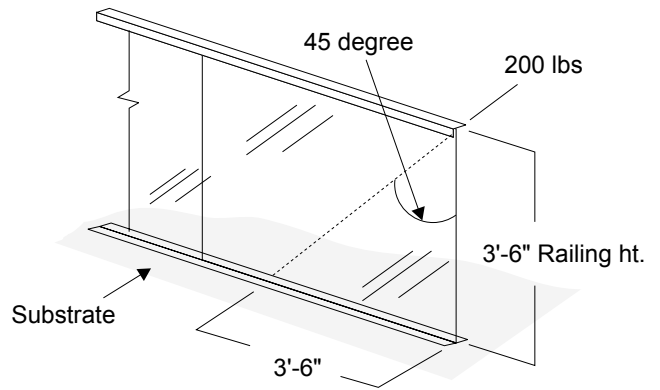

200 lbs at end of railing  
 (into page - see above)

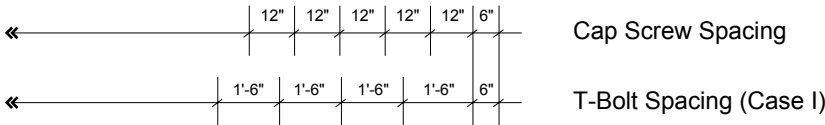
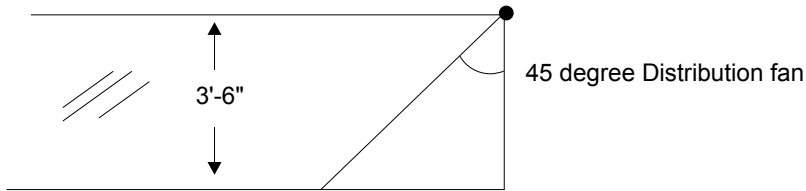

Maximum end distance assumed

# ANALYSIS OF GLASS RAIL BASE MOLDING ATTACHMENT

<b>Wiss, Janny, Elstner Associates, Inc.</b> 330 Pfingsten Rd., Nor thbrook Illinois 60062		Made by: <b>NSA</b>	Sheet # <b>6/21</b>
	<b>TACO Metals</b> 50 N.E 179th Street, Miami FL 33162 <b>Glass Rail Base Molding Attachment Analysis</b>		Checked by: <b>MJS</b>
			Date: <b>07/22/97</b>

## Material Assumptions

- Cap Screws  
     SAE Grade 5, 1/2"  $\varnothing$  Screws  
      $F_u = 120$  ksi (ultimate)
- T-Bolts  
     ASTM A307, 3/8"  $\varnothing$   
      $F_y = 92$  ksi (yield)  
      $F_u = 60$  ksi (ultimate)
- Aluminum Base Shoe Molding  
     Alloy 6063 -T6
- Concrete (Substrate)  
      $F_c = 4000$  psi (minimum)
- Steel (Substrate)  
     ASTM A36  $F_y = 36$  ksi (minimum)

## Base Shoe Connection Types

- Case 1      Concrete surface mounted      (recessed molding)
- Case 2      Concrete flush mounted      (vertically attached)
- Case 3      Steel fascia mounted      (horizontally attached)
- Case 4      Steel fascia mounted



# ANALYSIS OF GLASS RAIL BASE MOLDING ATTACHMENT

<b>Wiss, Janny, Elstner Associates, Inc.</b> 330 Pfingsten Rd., Nor thbrook Illinois 60062		Made by: <b>NSA</b>	Sheet # <b>8/21</b>
	<b>TACO Metals</b> 50 N.E 179th Street, Miami FL 33162 <b>Glass Rail Base Molding Attachment Analysis</b>		Checked by: <b>MJS</b>
			Date: <b>07/22/97</b>

## Tensile Allowable

$$F_t = 0.33 F_U \text{ (AISC Manual of Steel Construction)}$$

$$= 0.33(120 \text{ ksi}) = 40 \text{ ksi}$$

$$\text{Area} = \pi d^2 / 4 = \pi (.5)^2 / 4 = 0.196 \text{ sq. in.}$$

$$T_{\text{allow}} = F_t A = (40 \text{ ksi})(0.196 \text{ in}^2) = 7.84 \text{ kips} = 7840 \text{ lbs}$$

$$7840 \# > 2240 \text{ lbs} \quad \text{ok}$$

## Shear Load on Cap Screw

$$V = 200/3 = 66.7 \text{ lbs}$$

## Shear Allowable

$$F_V = 0.17 F_U \text{ (AISC Manual - threads included)}$$

$$= 0.17 (120) = 20.4 \text{ ksi}$$

$$V_{\text{allow}} = F_V A = (20.4 \text{ ksi})(0.96 \text{ in}^2) = 3.99 \text{ kips} = 4000 \text{ lbs}$$

$$4000 > 66.7 \quad \text{ok}$$

## Combined

By observation → ok

## Check Screw Bearing on Aluminum

Screw shank length brg on AL:  $3/4" - 0.21 = 0.54 \text{ in}$  ← Countersunk Head  
 (Ref. IFI Stds)  $3/4" - 0.5 \text{ in} = 0.25 \text{ in}$  ← Socket Head

$$\text{Bearing Area} = (.5)(.25 \text{ in}) = 0.125 \text{ in}^2$$

Allowable bearing stress on aluminum (Aluminum Spec. '94)

Table 2-23  $F_p = 24 \text{ ksi}$

# ANALYSIS OF GLASS RAIL BASE MOLDING ATTACHMENT

<b>Wiss, Janny, Elstner Associates, Inc.</b> 330 Pfingsten Rd., Northbrook Illinois 60062		Made by: <b>NSA</b>	Sheet # <b>9/21</b>
	<b>TACO Metals</b> 50 N.E 179th Street, Miami FL 33162 <b>Glass Rail Base Molding Attachment Analysis</b>		Checked by: <b>MJS</b>
			Date: <b>07/22/97</b>

$$V_{allow} = F_p A_{brg} = (24 \text{ ksi})(0.125 \text{ in}) = 3.0 \text{ kips}$$

$$3000 \text{ lbs} > 66.7 \text{ lbs} \quad \text{ok}$$

## Check Screw Pullout in Aluminum

Countersunk Head

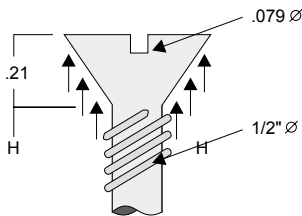

$$A_p = \pi/4 (.79^2 - .5^2)$$

$$= 0.294 \text{ in}^2$$

$$A_v = \pi dh$$

$$= \pi(.79)(3/4 - .21)$$

$$= 1.34 \text{ in}^2$$

Socket Head

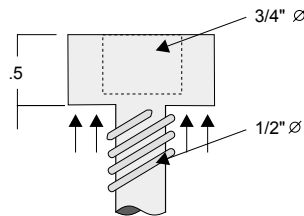

$$A_p = \pi/4 (.75^2 - .5^2)$$

$$= 0.245 \text{ in}^2$$

$$A_v = \pi dh$$

$$= \pi(.75)(.25)$$

$$= 0.589 \text{ in}^2 \quad \leftarrow \text{critical}$$

### ~ Bearing Under Head

$$F_p = 16 \text{ ksi (conservative) on Flat surfaces} \sim \text{brg.}$$

$$T_{allow} = F_p A_p = (16 \text{ ksi})(.245 \text{ in}^2) = 3.92 \text{ kips} = 3920 \text{ lbs}$$

$$> 2240 \text{ lbs} \quad \text{ok}$$

### ~ Shear Plug

$$F_v = 8.5 \text{ ksi (Aluminum Spec '94)}$$

$$V_{allow} = F_u A_u = (8.5 \text{ ksi})(.589 \text{ in}^2) = 5 \text{ kips}$$

$$> 2240 \text{ lbs} \quad \text{ok}$$

# ANALYSIS OF GLASS RAIL BASE MOLDING ATTACHMENT

<b>Wiss, Janny, Elstner Associates, Inc.</b> 330 Pfingsten Rd., Nor thbrook Illinois 60062	Made by: <b>NSA</b>	Sheet # <b>10/21</b>
 TACO Metals 50 N.E 179th Street, Miami FL 33162 <b>Glass Rail Base Molding Attachment Analysis</b>	Checked by: <b>MJS</b>	Project # <b>970798</b>
	Date: <b>07/22/97</b>	

## Cap Screw into Steel Plate

1/2" thick Steel Plate

(Ref: "Metal Curtain Wall Fasteners", from AAMA)

Table 4 Thread Stripping Area - Internal (sq. in. / thread)

$$1/2" \varnothing \quad TSA(l) = 0.036$$

Number of Threads / Inch  $N = 13$  (UNC)

$$\text{Min. PL - Thickness to achieve Tension Force} = \frac{\text{Allowable Tension}}{\text{Allow. Shear Stress} \cdot TSA(l) \cdot (N) + \frac{1}{N}}$$

$$MT = \frac{7840 \text{ lbs}}{(.4)(36,000)(0.86)(13) + \frac{1}{13}}$$

$$F_v = .4F_y$$

$$\frac{7840}{16099 + 13} = 0.56 \text{ in} \quad 1/2" \text{ PL provided}$$

$$\text{Reduction Factor} = .5 / .56 = 0.88$$

$$T_{\text{allow}} = (7840 \text{ lbs})(.88) = 6900 \text{ lbs}$$

>2240 lbs ok

## Anchor in Concrete (Steel check)

3/8"  $\varnothing$  A307 bolts assumed to act as studs.

Bolt Tension

4 in wide plate assume Arm = 4/2 = 2 in

On page 1, 2 stud bolts assumed effective

$$T = \frac{M}{\text{Arm}} = \frac{8400 \text{ in lbs}}{(2 \text{ in})(2 \text{ bolts})} = 2100 \text{ lbs/bolt}$$



# ANALYSIS OF GLASS RAIL BASE MOLDING ATTACHMENT

<b>Wiss, Janny, Elstner Associates, Inc.</b> 330 Pfingsten Rd., Nor thbrook Illinois 60062		Made by: <b>NSA</b>	Sheet # <b>12/21</b>
	<b>TACO Metals</b> 50 N.E 179th Street, Miami FL 33162 <b>Glass Rail Base Molding Attachment Analysis</b>		Checked by: <b>MJS</b>
			Date: <b>07/22/97</b>

## Check Steel Plate

1/2" thick  $F_L$  , studs at 18in oc.

Assume 6" of plate is tributary to resist bending

$$s = \frac{bd^2}{6} = \frac{(6'')(0.5'')^2}{6} = 0.25 \text{ in}^3$$

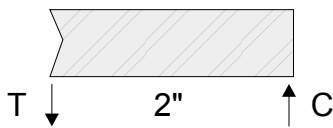

$$= 2100 \text{ lbs}$$

$$M = (2100 \text{ lbs})(2'') = 4200 \text{ in lbs}$$

$$F_b = \frac{m}{s} = \frac{(4.2 \text{ in kips})}{.25 \text{ in}^3} = 16.8 \text{ ksi}$$

$$F_b = 0.75 F_y = 0.75 (36) = 27 \text{ kis } \quad \underline{\text{ok}}$$

## Check Stud in Concrete

(Ref: PCI Design Handbook, 4th edition, Chapter 6)

Factored Loads (refer to pages 6& 7)

$$V = (100 \text{ lbs})(1.7) = 170 \text{ lbs}$$

$$T = (2100 \text{ lbs})(1.7) = 3570 \text{ lbs}$$

## Bolt Geometry

As a practical minimum, select a 3" long bolt

(AISC Manual) 3/8" hex head bolty  $F = 9/16''$  (dist. across flats)

## Pull - Out Cone (Tension)

$$l_e = 3 \text{ in} \quad A_o = \sqrt{2} l_e \pi (l_e = d_h)$$

$$d_h = 9/16 \text{ in} \quad = \sqrt{2} (3) (\pi) [3.5625''] = 47.5 \text{ in}^2$$

# ANALYSIS OF GLASS RAIL BASE MOLDING ATTACHMENT

<b>Wiss, Janny, Elstner Associates, Inc.</b> 330 Pfingsten Rd., Nor thbrook Illinois 60062	Made by: <b>NSA</b>	Sheet # <b>13/21</b>
 <b>TACO Metals</b> 50 N.E 179th Street, Miami FL 33162 <b>Glass Rail Base Molding Attachment Analysis</b>	Checked by: <b>MJS</b>	Project # <b>970798</b>
	Date: <b>07/22/97</b>	

$F'_c = 4000$  psi (mimimum)

$$\begin{aligned}
 | P_c &= | A_o (2.8 \times \sqrt{F'_c}) \\
 &= (0.85) (47.5) (2.8) \sqrt{4000} \\
 &= 7150 \text{ lbs} \quad > 3570 \text{ obs ok}
 \end{aligned}$$

## Shear

Min. edge distance =  $15d_b = 15 (3/8") = 5.625$  in

$$\begin{aligned}
 | V_c &= | 628d_b^2 \lambda \sqrt{f'_c} \eta \quad \text{where } \eta = \text{number of studs} \\
 &= (.85) (628) (.375)^2 (1.0) \sqrt{4000} (1.0) \\
 &= 4750 \text{ lbs} \quad > 170 \text{ lbs ok}
 \end{aligned}$$

## Examine Shear Parameters

Bolt length + R Thickness =  $3" + 1/2" = 3 \ 1/2"$   
 Say practical min. edge dist. =  $1.5 (3.5) = 5 \ 1/4" = d_e$

$$\begin{aligned}
 | V_c &= | 12.5 d_e^{1.5} \lambda \sqrt{f'_c} \\
 &= (.85)(12.5)(5.25)^{1.5} (1.0) \sqrt{4000} = 8085 \text{ lbs}
 \end{aligned}$$

\* Width Effect  $C_w = 1.0$  (only one stud in group)

\* Thickness Effect =  $\frac{h}{C_t} \leq 1.0$   
 $C_t = 1.3d_e$

Only becomes a factor when  $h < 1.3(5 \ 1/4) = 6 \ 7/8"$

$$\text{Select } h = 5 \text{ in} \quad C_t = \frac{5}{6.875} = 0.73$$

\* Corner Effect  $C_c = 1.0$

→ Keep edge distance > 5 1/4" in both directions.

# ANALYSIS OF GLASS RAIL BASE MOLDING ATTACHMENT

<b>Wiss, Janny, Elstner Associates, Inc.</b> 330 Pfingsten Rd., Nor thbrook Illinois 60062	Made by: <div style="text-align: center; font-weight: bold; font-size: 1.2em;">NSA</div>	Sheet # <div style="text-align: center; font-weight: bold; font-size: 1.2em;">14/21</div>
<b>TACO Metals</b> 50 N.E 179th Street, Miami FL 33162 <b>Glass Rail Base Molding Attachment Analysis</b>	Checked by: <div style="text-align: center; font-weight: bold; font-size: 1.2em;">MJS</div>	Project # <div style="text-align: center; font-weight: bold; font-size: 1.2em;">970798</div>
	Date: <div style="text-align: center; font-weight: bold; font-size: 1.2em;">07/22/97</div>	

$$\begin{aligned}
 |V_c &= |V'_c C_w C_t C_c \\
 &= (8085 \text{ lbs.}) (1.0) (0.73) (1.0) \\
 &= 5092 \text{ lbs}
 \end{aligned}$$

Other eqn still governs

(Note: A 5" min. slab thickness is a practical minimum for this PL & bolt combination)

## Check Combined

$$P_c = 7150 / .85 = 8412 \text{ lbs}$$

$$V_c = 4750 / .85 = 5588 \text{ lbs}$$

$$\frac{1}{1} \left[ \left( \frac{P_u}{P_c} \right)^2 + \left( \frac{V_u}{V_c} \right)^2 \right] \leq 1.0$$

$$\frac{1}{.85} \left[ \left( \frac{3750}{8412} \right)^2 + \left( \frac{170}{5588} \right)^2 \right] \leq 1.0$$

$$\frac{1}{.85} [ .18 + .001 ] \leq 1.0$$

$$0.2 \leq 1.0 \quad \text{ok}$$

## Weld bolt to plate

$$3/8" \text{ } \emptyset \quad \text{Length} = 2 \pi r = (3/8") (\pi) = 1.178$$

$$T = 2100 \text{ lbs} = 2.1 \text{ kips}$$

$$V = 100 \text{ lbs} = 0.1 \text{ kips}$$

$$\text{E70 electrodes} \quad F_v = (.3) (70 \text{ ksi}) = 21 \text{ ksi}$$

$$\begin{aligned}
 3/16" \text{ weld} \quad R_w (3/16") (.707) (21 \text{ ksi}) (1.178") \\
 = 3.3 \text{ kips} \quad \text{ok}
 \end{aligned}$$

No need to check interaction as tension dominates

# ANALYSIS OF GLASS RAIL BASE MOLDING ATTACHMENT

<b>Wiss, Janny, Elstner Associates, Inc.</b> 330 Pfingsten Rd., Northbrook Illinois 60062	Made by: <b>NSA</b>	Sheet # <b>15/21</b>
<b>TACO Metals</b> 50 N.E 179th Street, Miami FL 33162 <b>Glass Rail Base Molding Attachment Analysis</b>	Checked by: <b>MJS</b>	Project # <b>970798</b>
	Date: <b>07/22/97</b>	

### Case 2 Analysis

Configuration

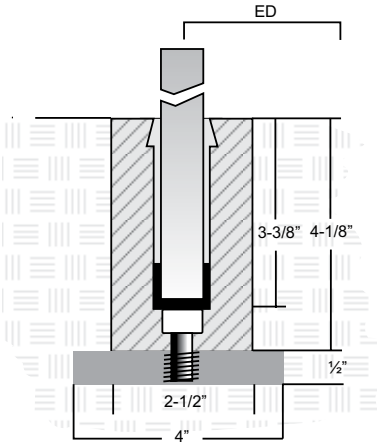

200 lbs over 42" width  
 $M = (200) (42) = 8400 \text{ in lbs}$   
 $= 8.4 \text{ in kips}$   
 (at finish floor elev.)

$M = (200) (42" + 4 \frac{1}{8}" )$   
 $= 9225 \text{ in lbs}$   
 $Mu = 1.7 (9.23)$   
 $= 15.7 \text{ in kips}$

$Vu = 1.7 (0.2) = 0.34 \text{ kips}$

Evaluate a Resisting Couple in the Molding

FBD

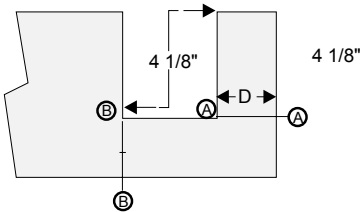

$N \approx M = 15.7 / 4.125 = 3.81 \text{ kips}$   
 $4 \frac{1}{8}"$

or

$MA = N(4 \frac{1}{8}" ) = 15.7 \text{ in kips}$

Section A-A

Analyze as a plain concrete section  
 (Ref: ACI 318-95)  
 Section 9.3.5  $\lambda = 0.65$  Strength reduction factor  
 Chapter 22 ~ Structural Plain Concrete  
 $Mu = \lambda Mn = \lambda 5 \sqrt{f'c} S$  [Eq'n 22-2]

# ANALYSIS OF GLASS RAIL BASE MOLDING ATTACHMENT

<b>Wiss, Janny, Elstner Associates, Inc.</b> 330 Pfingsten Rd., Northbrook Illinois 60062	Made by: <b>NSA</b>	Sheet # <b>16/21</b>
 TACO Metals 50 N.E 179th Street, Miami FL 33162 <b>Glass Rail Base Molding Attachment Analysis</b>	Checked by: <b>MJS</b>	Project # <b>970798</b>
	Date: <b>07/22/97</b>	

Determine req'd section modulus ~ S

$$M_u = 1.5 \sqrt{f_c} S$$

$$S = \frac{M_u}{1.5 \sqrt{f_c}} = \frac{15,700 \text{ in lbs}}{(.65)(5) \sqrt{4000}}$$

Determine min. width req'd

$$5 = \frac{bd^2}{6} \quad d = \sqrt{\frac{65}{b}} = \sqrt{\frac{6(76.4)}{42}} = 3.3 \text{ in}$$

where b = 42" (effective width resisting the load, p.1)

From center of railing to edge

$$ED = 4/2 + 3.3 = 5.3 \text{ in} \quad \text{say } 5 \frac{1}{2} \text{ in.}$$

~ Shear across interface

$$\begin{aligned}
 |V_n| &= 1(4/3) \sqrt{f_c} b_h \quad [\text{Eq'n 22-8}] \\
 &= (6.5)(4/3) \sqrt{4000} (42")(3.5)(1/1000) \\
 &= 8.1 \text{ kips} \quad \text{ok}
 \end{aligned}$$

## Section B-B

Slight increase in moment; the depth at B-B will be at least 3 1/2"

$$\begin{aligned}
 \text{Arm} &= (42" + 4 \frac{5}{8}" + 3.5/2) = 48.375 \\
 M_u &= (1.7)(48.375)(0.2 \text{ kips}) = 16.45 \text{ in kips}
 \end{aligned}$$

~ Check 3 1/2 in of concrete below R

$$S = \frac{bd^2}{6} = \frac{(42")(3.5)^2}{6} = 85.75 \text{ in}^3$$

$$\begin{aligned}
 |M_n| &= 1.5 \sqrt{f_c} S = (.65)(5) \sqrt{4000} (85.75)(1/1000) \\
 &= 17.63 \text{ in kips} > 16.45 \text{ in kips} \quad \text{ok}
 \end{aligned}$$

# ANALYSIS OF GLASS RAIL BASE MOLDING ATTACHMENT

<b>Wiss, Janny, Elstner Associates, Inc.</b> 330 Pfingsten Rd., Nor thbrook Illinois 60062	Made by: <b>NSA</b>	Sheet # <b>17/21</b>
 <b>TACO Metals</b> 50 N.E 179th Street, Miami FL 33162 <b>Glass Rail Base Molding Attachment Analysis</b>	Checked by: <b>MJS</b>	Project # <b>970798</b>
	Date: <b>07/22/97</b>	

~ Shear across section

Glass weighs 15 psf/lin thickness

3/4" thick glass ~w = 11.3 psf

1 ft width:

$$w = (11.3 \text{ psf}) (4 \text{ ft}) = 45.2 \text{ lbs/ft.}$$

Where 4 ft height includes top hardrail wt. (approx)

$$W_u = (1.4) (45.2/\text{ft.}) + (1.7) (50) = 148 \text{ lbs over 1 ft}$$

Effective Width = 3.5 ft

$$W_u (148 \text{ lbs/ft}) (3.5 \text{ ft}) = 520 \text{ lbs} \ll 8.1 \text{ kips} \quad \text{ok}$$

## Evaluate a Resisting Couple in the Steel Plate

FBD

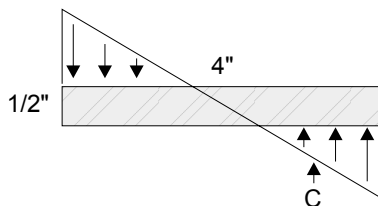

$$M = 15.7 \text{ in. kips}$$

$$\text{Arms} = 2/3 (4") = 2.667"$$

$$C \approx \frac{15.7}{2.667} = 5.9 \text{ kips}$$

By inspection, the concrete section (3 1/2" min.) below this has the necessary capacity to resist the moment & shear ( C force) at the previously identified section B-B.

At the top, the upward reacting C force acts over an area:

$$A = (3/4") (42") = 31.5 \text{ sq. in.}$$

Check concrete bearing

$$F_p = \frac{5900 \text{ lbs}}{31.5 \text{ in}^2} = 187 \text{ psi}$$

Allowable [ACI 22.5.5]

$$F_p = 10.85f_c = (.65) (.85) (4000 \text{ psi}) = 2210 \text{ psi} \quad \text{ok}$$

# ANALYSIS OF GLASS RAIL BASE MOLDING ATTACHMENT

<b>Wiss, Janny, Elstner Associates, Inc.</b> 330 Pfingsten Rd., Nor thbrook Illinois 60062		Made by: <b>NSA</b>	Sheet # <b>18/21</b>
	TACO Metals 50 N.E 179th Street, Miami FL 33162 <b>Glass Rail Base Molding Attachment Analysis</b>	Checked by: <b>MJS</b>	Project #
		Date: <b>07/22/97</b>	<b>970798</b>

## Evaluate Cap Screw Fastener

Moment slightly higher  $M = 9225$  in lbs (see page 11)

$T = M/1.25" = 9225/1.5 = 7380$  lbs

3 cap screws effective  $7380/3 = 2460$  lbs

### Allowables

(page 4) screw tensile allowable = 7840 lbs → ok

(page 5) tensile brg under head = 3920 lbs → ok

: screw connection remains ok

# ANALYSIS OF GLASS RAIL BASE MOLDING ATTACHMENT

<b>Wiss, Janny, Elstner Associates, Inc.</b> 330 Pfingsten Rd., Nor thbrook Illinois 60062	Made by: <b>NSA</b>	Sheet # <b>19/21</b>
 <b>TACO Metals</b> 50 N.E 179th Street, Miami FL 33162 <b>Glass Rail Base Molding Attachment Analysis</b>	Checked by: <b>MJS</b>	Project # <b>970798</b>
	Date: <b>07/22/97</b>	

## Case 3 Analysis: Configuration

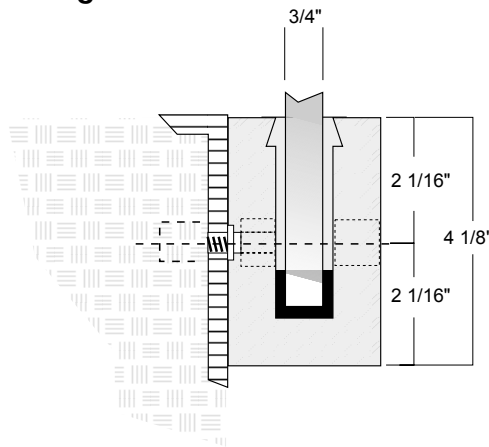

( from page 11 & 13)  
 conservatively say  
 $M = 9225$  in lbs  
 $N = 200$  lbs  $\rightarrow$   
 $P =$  glass wt.  
 $= (3.5') ( 45 \text{ lbs/ft} )$   
 $= 158$  lbs  $\downarrow$

## Cap Screw Connection

Tensile Load on One Cap Screw  
 Again, conservatively assume that 3 screws are effective

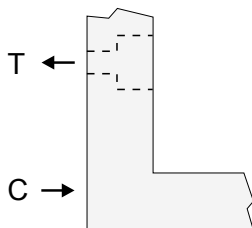

Arm =  $2 \frac{1}{16}$ "

$$T = \frac{M}{\text{Arm}} = \frac{9225 \text{ in lbs}}{(2 \frac{1}{16}) (3 \text{ screws})} = 1491 \text{ lbs}$$

(page 4) T allow = 7840 lbs    ok

## Shear Load on Cap Screw

$$V = 520/3 = 173 \text{ lbs}$$

(page 4) V allow = 4000 lbs    ok



# ANALYSIS OF GLASS RAIL BASE MOLDING ATTACHMENT

<b>Wiss, Janny, Elstner Associates, Inc.</b> 330 Pfingsten Rd., Northbrook Illinois 60062	Made by: <b>NSA</b>	Sheet # <b>21/21</b>
 <b>TACO Metals</b> 50 N.E 179th Street, Miami FL 33162 <b>Glass Rail Base Molding Attachment Analysis</b>	Checked by: <b>MJS</b>	Project # <b>970798</b>
	Date: <b>07/22/97</b>	

**Case 4 Analysis: Configuration**

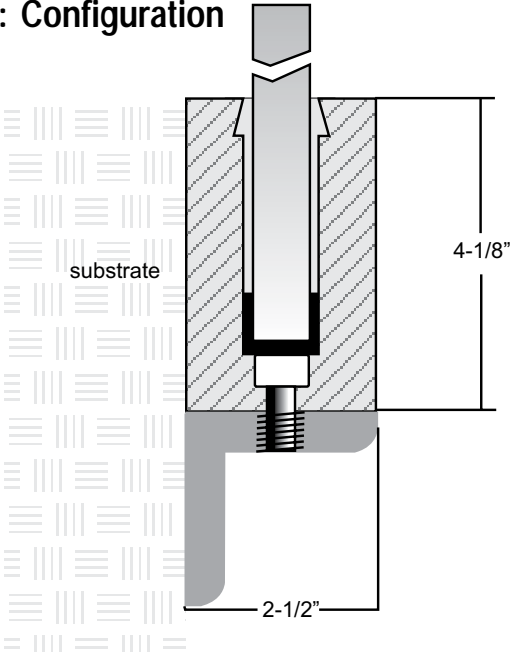

( from page 11 & 13 )  
 M = 9225 in lbs  
 N = 200 lbs →  
                   DL  
 P = (3.5') (45)  
       = 158 lbs ↓

**Cap Screw Connection**

Arm = (2 1/2) (1/2) = 1 1/4"    Again, 3 screws effective  

$$T = \frac{M}{\text{Arm}} + \frac{9225}{(3)(1.25)} = 2460 \text{ lbs}$$

- (page 4)     T allow = 7840 lbs    ok
- (page 5)     T allow = 3920 lbs    ok    (brg under head)
- (page 16)    T allow = 5250 lbs    ok    (3/8" RL grip)