

▶ Q-SAFETY - TÜV

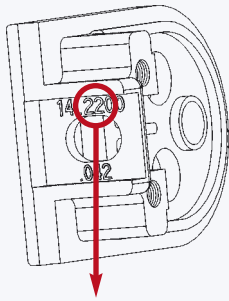
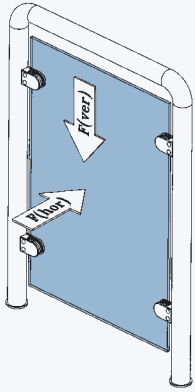

Glass clamp model

Permittable forces for safety glass

$F(ver)$: Max. permittable vertical force for 4 glass clamps (without security pin)

$F(hor)$: Max. permittable horizontal force for 4 glass clamps

Glass clamp model	$F(ver)$	$F(hor)$
20	100 kg	300 kg
21	100 kg	300 kg
22	100 kg	300 kg



▶ Q-SAFETY - ETB



When glass is being used in balustrading or staircases, safety is an important matter when it comes to the combination glass and glass clamps.

According to these rules the glass clamps must resist a horizontal minimum force of 280 kg.

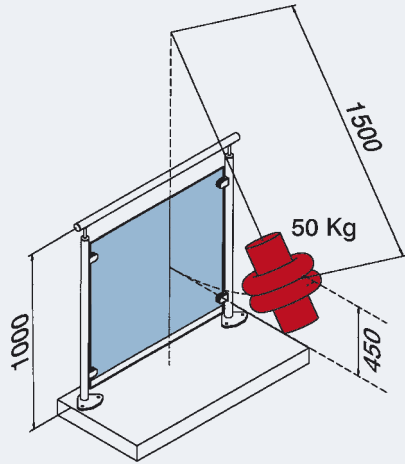

**EN 12600**

Approved glass clamps for your safety

In a further test, the glass clamps and the glass is tested according to the European norm EN 12600. This test simulates an accident of a falling person, comprising of a 50 kg pendulum weight. The glass clamps and glass combined will prevent the person falling through.

All Q-railing glass clamps from 8 mm glass have resisted this heavy European norm. The test results as well as the recommended glass dimensions you will find on the next 4 pages.

(Indoor tests: Tested by Technical University Munich
Outdoor tests: Tested by German engineering institution, Dr.Ronald Ondra and LGA Nurnberg)

The test results required are the highest standard for German technical approval and the highest norm for the German building sector.

■ The advantages of Q-railing glass clamps

- Certified clamps for fast approval.
- Glass width maximum 1600 mm.
- All glass clamps have been tested for Monolithic and laminated glass.
- Tested for indoor and outdoor applications.

Glass clamps without security pin
and without security plate

INDOOR

Models
20, 21, 22,
24, 25, 26

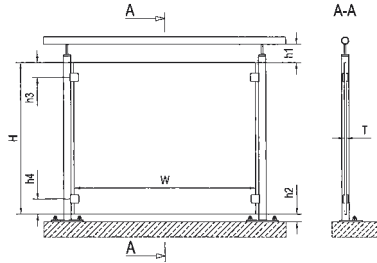

Models
40, 41

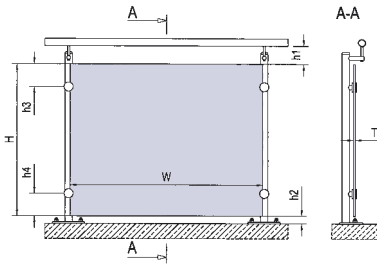

Dimensions (mm)		min.	max.
W	Width of glass	500	see corresponding model
T	Glass thickness	see corresponding model	see corresponding model
H	Height of glass	800	1000
h1	Distance handrailing - glass	10	50 without edge protection 120 with edge protection
h2	Distance bottom - glass	10	50 without edge protection 120 with edge protection
h3	Glass edge above - Axle upper glass clamp	100	150
h4	Glass edge below - Axle lower glass clamp	100	150

316 (V4A) Zintec	Flat connection	Tube connection	Glass structure / Glass type *	W (mm)	T (mm)
Model 20		 for tube Ø 33,7 mm Ø 42,4 mm	ESG-H	500 - 1200	8
Model 21		 for tube Ø 42,4 mm	VSG / ESG	500 - 1200	8,76 / 9,52
Model 22		 for tube Ø 42,4 mm Ø 48,3 mm	VSG / TVG VSG / ESG Mono / ESG-H	500 - 1500 500 - 1500 500 - 1500	8,76 / 9,52 8,76 / 9,52 8 / 10
Model 24		 for tube Ø 48,3 mm	VSG / SPG VSG / TVG VSG / ESG Mono / ESG-H	500 - 1500 500 - 1500 500 - 1600 500 - 1600	12,76 / 16,76 / 13,52 / 17,52 12,76 / 16,76 / 13,52 / 17,52 12,76 / 16,76 / 13,52 / 17,52 12 / 16
Model 25		 for tube Ø 42,4 mm Ø 48,3 mm	VSG / TVG VSG / ESG Mono / ESG-H	500 - 1500 500 - 1500 500 - 1600 500 - 1500	10,76 / 12,76 / 11,52 10,76 / 11,52 12,76 12
Model 26		 for tube Ø 42,4 mm Ø 48,3 mm	VSG / TVG VSG / ESG Mono / ESG-H	500 - 1400 500 - 1400 500 - 1400	8,76 / 10,76 / 12,76 / 9,52 / 11,52 8,76 / 10,76 / 12,76 / 9,52 / 11,52 8 / 10 / 12
Model 40 only in 316 (V4A)		 for tube Ø 42,4 mm Ø 48,3 mm	VSG / ESG Mono / ESG-H	500 - 1200 500 - 1200	8,76 / 10,76 / 12,76 8 / 10 / 12
Model 41 only in 316 (V4A)		 for tube Ø 42,4 mm Ø 48,3 mm	VSG / ESG Mono / ESG-H	500 - 1200 500 - 1200	8,76 / 10,76 / 12,76 8 / 10 / 12

* SPG: Float • TVG: Heat strengthened • ESG: Toughened • Mono: Monolithic • VSG: Laminated • ESG-H: Toughened-H

OUTDOOR

Possible width of glass for outdoor use depending on wind factor, glass type and glass thickness - without security pin and without security plate

Model 22



max. width of glass (mm)			VSG				Mono	
			TVG		ESG		ESG	
		Height	8,76	9,52	8,76	9,52	8	10
-2,20 kN / m \approx	W	<= 100 m					800	800
-1,60 kN / m \approx	W	<= 20 m			500	500	1000	1400
1,40 kN / m \approx	N	<= 100 m			500	500	1000	1400
1,04 kN / m \approx	N	<= 20 m	500	500	800	800	1400	1500
-1,00 kN / m \approx	W	<= 8 m	500	500	1000	1000	1400	1500
0,64 kN / m \approx	N	<= 8 m	800	800	1200	1200	1500	1500

W = Corner situation
N = Normal situation

Model 24



max. width of glass (mm)			VSG											Mono		
			SPG				TVG				ESG			ESG		
		Height	12,76	13,52	16,76	17,52	12,76	13,52	16,76	17,52	12,76	13,52	16,76	17,52	12	16
-2,20 kN / m \approx	W	<= 100 m	500	500	800	800	500	500	1000	1000	1000	1000	1200	1200	1400	1600
-1,60 kN / m \approx	W	<= 20 m	500	500	1000	1000	800	800	1200	1200	1200	1200	1500	1500	1600	1600
1,40 kN / m \approx	N	<= 100 m	800	800	1000	1000	800	800	1200	1200	1200	1200	1600	1600	1600	1600
1,04 kN / m \approx	N	<= 20 m	800	800	1200	1200	1000	1000	1500	1500	1400	1400	1600	1600	1600	1600
-1,00 kN / m \approx	W	<= 8 m	1000	1000	1200	1200	1000	1000	1500	1500	1500	1500	1600	1600	1600	1600
0,64 kN / m \approx	N	<= 8 m	1200	1200	1500	1500	1500	1500	1500	1500	1600	1600	1600	1600	1600	1600

W = Corner situation
N = Normal situation

Model 25



max. width of glass (mm)			VSG						Mono
			TVG			ESG			ESG
		Height	10,76	11,52	12,76	10,76	11,52	12,76	12
-2,20 kN / m \approx	W	<= 100 m	500	500	500	800	800	800	1400
-1,60 kN / m \approx	W	<= 20 m	500	500	800	800	800	1200	1500
1,40 kN / m \approx	N	<= 100 m	500	500	800	800	800	1200	1500
1,04 kN / m \approx	N	<= 20 m	800	800	800	1200	1200	1400	1500
-1,00 kN / m \approx	W	<= 8 m	800	800	800	1200	1200	1500	1500
0,64 kN / m \approx	N	<= 8 m	1200	1200	1200	1500	1500	1500	1500

W = Corner situation
N = Normal situation

Model 26



max. width of glass (mm)			VSG									Mono			
			TVG				ESG					ESG			
		Height	8,76	9,52	10,76	11,52	12,76	8,76	9,52	10,76	11,52	12,76	8	10	12
-2,20 kN / m \approx	W	<= 100 m					500	500	500	800	800	800	800	1000	1400
-1,60 kN / m \approx	W	<= 20 m			500	500	800	800	800	800	800	1000	1000	1400	1400
1,40 kN / m \approx	N	<= 100 m			800	800	800	800	800	1000	1000	1200	1200	1400	1400
1,04 kN / m \approx	N	<= 20 m	500	500	800	800	1000	800	800	1000	1000	1400	1400	1400	1400
-1,00 kN / m \approx	W	<= 8 m	500	500	800	800	1000	800	800	1200	1200	1400	1400	1400	1400
0,64 kN / m \approx	N	<= 8 m	800	800	1000	1000	1200	1200	1200	1400	1400	1400	1400	1400	1400

W = Corner situation
N = Normal situation



**Glass clamps with security pin,
without security plate**

INDOOR

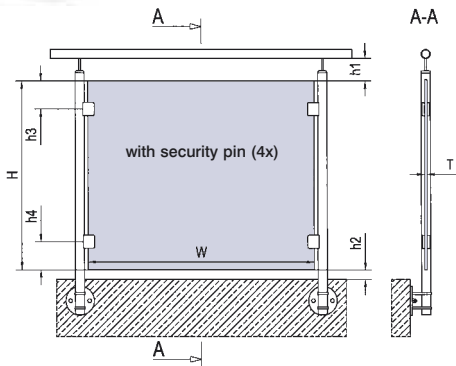

Dimensions (mm)		min.	max.
W	Width of glass	500	see corresponding model
T	Glass thickness	see corresponding model	see corresponding model
H	Height of glass	800	1000
h1	Distance handrailing - glass	10	50 without edge protection 120 with edge protection
h2	Distance bottom - glass	10	50 without edge protection 120 with edge protection
h3	Glass edge above - Axle upper glass clamp	150	150
h4	Glass edge below - Axle lower glass clamp	150	150

316 (V4A) Zintec	Flat connection	Tube connection	Glass structure / Glass type *	W (mm)	T (mm)
Model 24			VSG / ESG Mono / ESG-H	500 - 1600	12,76 / 16,76 / 13,52 / 17,52 12 / 16
Model 25			VSG / ESG	500 - 1600	12,76

* ESG: Toughened • Mono: Monolithic • VSG: Laminated • ESG-H: Toughened-H

OUTDOOR

**Possible width of glass for outdoor use depending on wind factor,
glass type and glass thickness -
with security pin, without security plate**

Model 24



max. width of glass (mm)			VSG				Mono	
			ESG				ESG	
	Height	12,76	13,52	16,76	17,52	12	16	
-2,20 kN / m ≈	W <= 100 m	500	500	1000	1000	1400	1600	
-1,60 kN / m ≈	W <= 20 m	800	800	1200	1200	1500	1600	
1,40 kN / m ≈	N <= 100 m	800	800	1400	1400	1600	1600	
1,04 kN / m ≈	N <= 20 m	1200	1200	1600	1600	1600	1600	
-1,00 kN / m ≈	W <= 8 m	1200	1200	1600	1600	1600	1600	
0,64 kN / m ≈	N <= 8 m	1500	1500	1600	1600	1600	1600	

W = Corner situation
N = Normal situation

Model 25



max. width of glass (mm)			VSG		
			ESG		
	Height	10,76	11,52	12,76	
-2,20 kN / m ≈	W <= 100 m	500	500	800	
-1,60 kN / m ≈	W <= 20 m	500	500	1000	
1,40 kN / m ≈	N <= 100 m	500	500	1000	
1,04 kN / m ≈	N <= 20 m	500	500	1400	
-1,00 kN / m ≈	W <= 8 m	500	500	1400	
0,64 kN / m ≈	N <= 8 m	500	500	1600	

W = Corner situation
N = Normal situation



**Glass clamps without security pin,
with security plate**

INDOOR

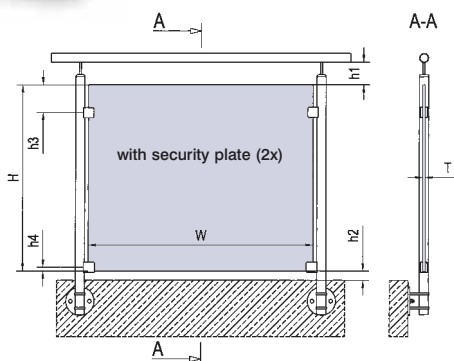

Dimensions (mm)		min.	max.
W	Width of glass	500	see corresponding model
T	Glass thickness	see corresponding model	see corresponding model
H	Height of glass	800	1000
h1	Distance handrailing - glass	10	50 without edge protection 120 with edge protection
h2	Distance bottom - glass	10	50 without edge protection 120 with edge protection
h3	Glass edge above - Axle upper glass clamp	100	150
h4	Glass edge below - Axle lower glass clamp	32 (Model 24) 21 (Model 26)	32 (Model 24) 21 (Model 26)

316 (V4A) Zintec	Flat connection	Tube connection	Glass structure / Glass type *	W (mm)	T (mm)
Model 24			VSG / TVG	500 - 1500	12,76 / 16,76 / 13,52 / 17,52
			VSG / ESG	500 - 1600	12,76 / 16,76 / 13,52 / 17,52
			Mono / ESG-H	500 - 1600	12 / 16
Model 26			VSG / ESG	500 - 1400	8,76 / 10,76 / 12,76 / 9,52 / 11,52
			Mono / ESG-H	500 - 1400	8 / 10 / 12

* TVG: Heat strengthened • ESG: Toughened • Mono: Monolithic • VSG: Laminated • ESG-H: Toughened-H

OUTDOOR

**Possible width of glass for outdoor use depending on wind factor,
glass type and glass thickness -
without security pin, with security plate**

Model 24



max. width of glass (mm)			VSG								Mono	
			TVG				ESG				ESG	
	Height		12,76	13,52	16,76	17,52	12,76	13,52	16,76	17,52	12	16
-2,20 kN / m \approx	W <= 100 m		500	500	500	500	500	500	1000	1000	1400	1600
-1,60 kN / m \approx	W <= 20 m		500	500	800	800	800	800	1200	1200	1500	1600
1,40 kN / m \approx	N <= 100 m		500	500	1000	1000	800	800	1400	1400	1600	1600
1,04 kN / m \approx	N <= 20 m		800	800	1200	1200	1200	1200	1600	1600	1600	1600
-1,00 kN / m \approx	W <= 8 m		800	800	1200	1200	1200	1200	1500	1500	1600	1600
0,64 kN / m \approx	N <= 8 m		1500	1500	1500	1500	1500	1500	1600	1600	1600	1600

W = Corner situation
N = Normal situation

Model 26



max. width of glass (mm)			VSG					Mono		
			ESG					ESG		
	Height		8,76	9,52	10,76	11,52	12,76	8	10	12
-2,20 kN / m \approx	W <= 100 m		500	500	800	800	800	800	1000	1400
-1,60 kN / m \approx	W <= 20 m		800	800	800	800	1000	1000	1400	1400
1,40 kN / m \approx	N <= 100 m		800	800	1000	1000	1200	1200	1400	1400
1,04 kN / m \approx	N <= 20 m		800	800	1000	1000	1400	1400	1400	1400
-1,00 kN / m \approx	W <= 8 m		800	800	1200	1200	1400	1400	1400	1400
0,64 kN / m \approx	N <= 8 m		1200	1200	1400	1400	1400	1400	1400	1400

W = Corner situation
N = Normal situation